

REVIEW: POTENTIAL EXAM QUESTIONS

The following questions are not part of your lab grade, **you won't be graded on the answers**. Questions like these – but not identical – may appear on the exam. You are welcome to discuss the questions and your answers with your fellow students or the instructors during your recitation/lab section.

The diagram below shows the equipotential contours from an unknown charge distribution.

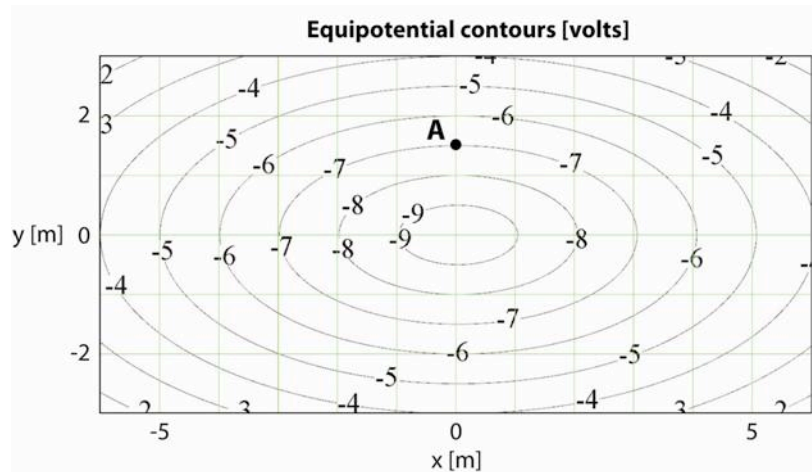

- What is the magnitude of the electric field at point A?
 - 0.5 V/m
 - 1.0 V/m
 - 2.0 V/m
 - 4.7 V/m
 - 7.0 V/m

- What is the direction of the electric field at point A?
 - +x
 - x
 - +y
 - y
 - Out of the page

3. An electron goes from one equipotential surface to another along one of the four paths shown in the diagram. Rank the paths according to the work done by the electric field, from least to greatest.

- $1 < 2 < 3 < 4$
- $4 < 3 < 2 < 1$
- $1 < 3 < 4 = 2$
- $4 = 2 < 3 < 1$
- $4 < 3 < 1 < 2$

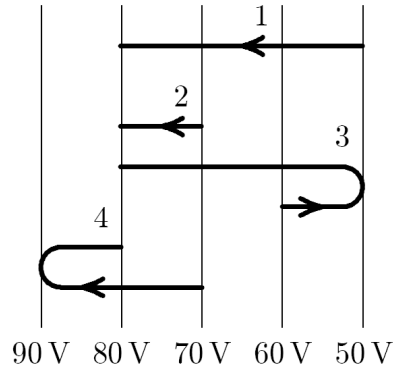

4. Adding a dielectric material between the plates of a capacitor connected to a battery has what effect?
- It increases the electric field between the plates
 - It decreases the energy stored in the capacitor
 - It increases the charge on the plates
 - It decreases the charge on the plates
 - More than one of the above is true
5. If the plate area of an isolated charged parallel-plate capacitor is doubled,
- the electric field is doubled
 - the potential difference is halved
 - the charge on each plate is halved
 - the surface charge density on each plate is doubled
 - none of the above

6. Three uniform copper cylinders with equal length are machined. The first cylinder has twice the radius of the second (i.e. $r_1=2r_2$), and half the radius of the third (i.e. $r_1=r_3/2$). Which cylinder has the largest resistance?
- Cylinder 1
 - Cylinder 2
 - Cylinder 3
 - All three have the same resistance.
 - Two of them have equal resistance.

7. Which of the following statements is true?

- When a real light bulb is on, the current into one of its terminals must be slightly greater than the current out of its other terminal.
- If two resistors are in series, the voltage difference across one resistor is always equal to the voltage difference across the other resistor.
- If wires are not ideal (i.e. they have internal resistance), then the total current into any junction can be unequal to the total current out of this junction (A junction is where three or more wires meet).
- In any circuit, the current is always flowing clockwise.
- In any closed circuit involving just resistors and batteries, the physical electrons flow from regions of lower voltage towards regions of higher voltage, but the "conventional current" flows the other way.

8. How much current is being supplied by the 12 V battery in the diagram?

- 0.2 A
- 0.5 A
- 1.0 A
- 2.0 A
- 3.0 A

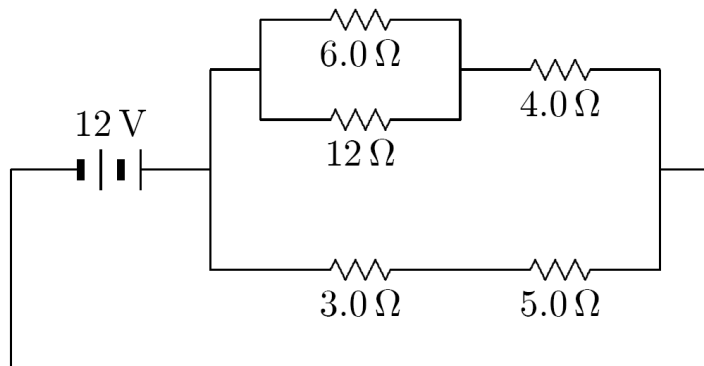

9. In the following diagram, what is the correct order of the voltage of the upper-right corner relative to ground, from lowest to highest? Assume all resistors are identical.

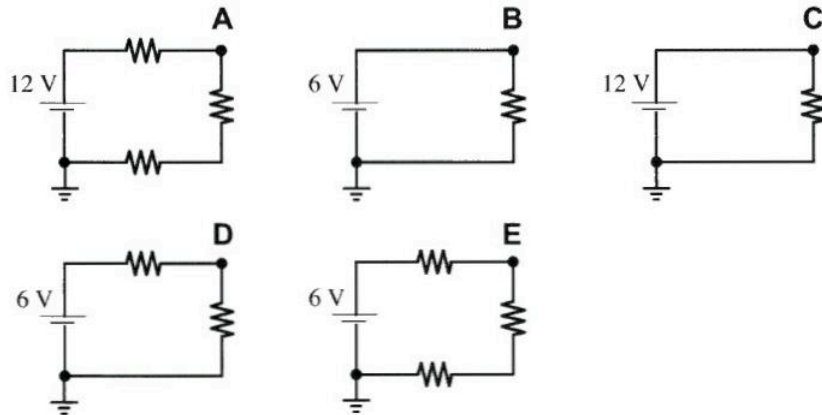

- a) C, A, B, E, D
 b) D, E, B, A, C
 c) A, E, D, C, B
 d) B, D, A, E, C
 e) B, E, D, C, A
10. You have two identical resistors and a battery (with no internal resistance). If you connect just one of the resistors to the battery, 30 watts of power is dissipated in the resistor. If you connect both resistors in series to the same battery, how much total power is dissipated in the resistors?
- a) 15 W
 b) 30 W
 c) 60 W
 d) 120 W
 e) 900 W

A circuit consists of two identical lightbulbs, with resistance labeled R . The battery is ideal, and is hooked up as shown. The third resistor is NOT a lightbulb, it is just a variable resistor!

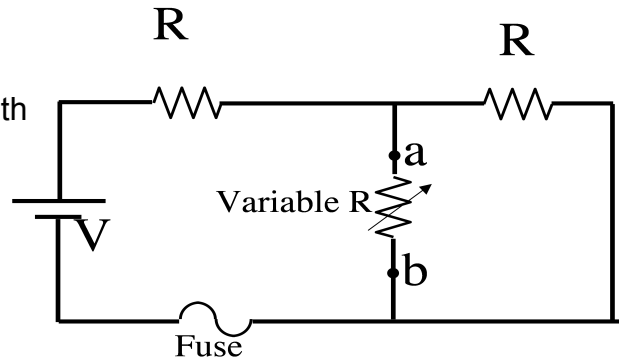

- I. At time $t=0$, the variable resistor has the same value R as the two bulbs. At this time (when all three resistances are the same)

Which of the two bulbs is brighter (or are they the same)? Which of the two bulbs has more current going through it (or are they the same)? Which of the two bulbs has more voltage drop across it (or are they the same)?
- II. Now suppose we INCREASE the variable resistor, to the limit of infinite resistance (this might also be equivalently described as "breaking the wire between a and b" or "opening a switch between a and b", do you see why?) Answer the above three questions again in this limit.

Is there anything physically unreasonable (or risky) about increasing the variable R ? Is the fuse more, less, or equally likely to "blow" in this limit compared to $t=0$.
- III. Now suppose we DECREASE the variable resistor, to the limit of zero resistance (this might also be equivalently described as "putting an ideal wire between a and b", or "short circuiting between points a and b", do you see why?) Answer all the above questions again in this limit.
- IV. Suppose the battery is a standard 6 V, and the lights each have resistance 1 Ohm each. For the three limiting cases described above (i.e. where the variable resistor is 1 Ohm, infinite, or 0 Ohm):

Compute the total power dissipated by the circuit

Compute the total power dissipated JUST by the two light bulbs.

If those two answers disagree for any case, briefly explain how/why that can be.

Finally - is the fuse in the right place in this circuit? (Where else could/should it go to serve the purpose of a fuse?)