

Giancoli Ch 18: Electric Currents

So far, we've considered *electrostatics*, charges which (pretty much) stay put. In the demos of sparking Van de Graafs, or discharging capacitors, we've seen the (important) effects of charges moving, which leads us to discuss the flow of charges: electric currents. This is where the action is, this is what household electronics is all about!

Electric Currents:

Whenever charges are free to move (e.g. in conductors), if you apply an \mathbf{E} field, they will move. (After all, $\mathbf{F} = q\mathbf{E} \Rightarrow$ acceleration!)

Imagine a wire, pick some spot, and ask yourself

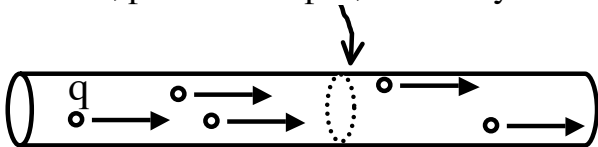

How much charge passes by that spot each second? That's the current.

Current is called $I = \frac{\Delta Q}{\Delta t}$, it's the (amount of charge passing) per sec.

(Often written Q/t for short).

The *units* of current are Coulombs/sec = C/s = 1 Ampere = 1 A.

So if $I = 1$ A, that means 1 Coulomb flows by each second. That's a lot!

Current has a *direction*. If the current is to the right, there's a net flow of charge to the right. This could occur in one of two ways:

It could mean "+"s physically moving to the right

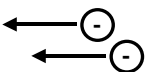
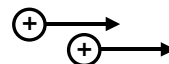

OR it could mean "-"s physically moving to the *left*.

There's (almost) no difference, in terms of "flow of charge". Think about this, it's an important point. Convince yourself! Negatives moving left are in most ways equivalent to positives moving right. The flow of charge is the same in either case.

Here's another way to think about this. Start with two neutral plates. Now, you could EITHER move some “-” charges down, OR move some “+” charges up, but either way, the final situation is the same.

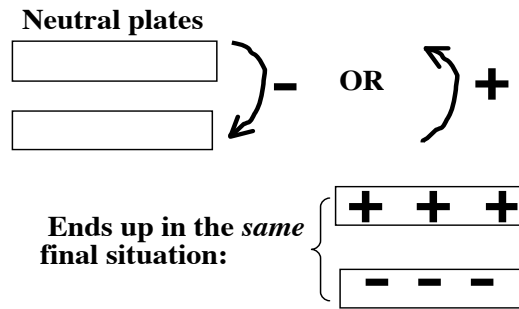

Our convention is always to define current I as the flow of imaginary “+” charges. (Even if in *reality* it's really negatives going the other way. In most conductors, it really *is* negative electrons flowing opposite the current.)

What *makes* currents flow? Generally, electric fields make charges move. You can also think of current as arising from changes in electric potential energy: a change in potential energy means you can convert potential energy into kinetic energy (motion), like a hill makes water flow down it...

Batteries:

Zinc ions (+ charged) get pulled off by *chemistry* (we won't go into the details!) into acid bath, leaving behind a residual “-” on the Zn rod (*terminal, electrode*).

Meanwhile, electrons (- charged) are pulled carbon rod into the acid bath, leaving a residual + charge on the Carbon side.

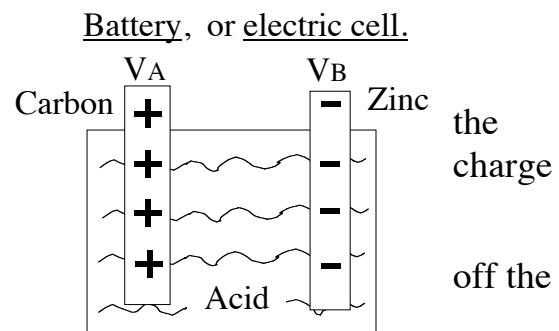

That means the carbon side is now at a *higher potential*, $V_A > V_B$. (Right? It's always higher voltage near the + charges, remember that?) This potential builds up, but if V_A gets *too* high, the acid can't pull electrons off any more (the electrostatic attraction of e^- 's back onto the + carbon rod will equal the chemical attraction of the e^- 's into the acid)

So you reach an equilibrium with

$$\Delta V = V_{AB} = V_A - V_B = \text{some fixed value depending on the chemicals.}$$

People usually drop the Δ , and just talk about “V”, the battery's voltage. (Too bad, remember they really *mean* the difference in voltage between the two electrodes.)

In diagrams, we use a symbol for batteries:

The “+” and “-“ are often left off: the longer line always represents the “+” side.

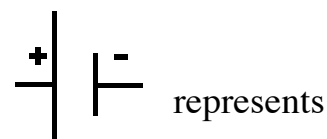

It’s a little like the symbol for capacitors, except the lines are different length. Capacitors and batteries have some common aspects, but they are still very different. Capacitors don’t spontaneously build up a ΔV , like batteries do, and they don’t always have the *same* value of ΔV .

You might expect that the “+” charges at the top of the C electrode would want to go over to the “-” post. They are attracted. The +’s would drop in energy, $\Delta PE = q\Delta V$: they’d like that, like rolling down a hill. They can’t go through the acid, though: the chemical reactions are stopping them. But what if you let them go some *other* way, outside of the acid? E.g.:

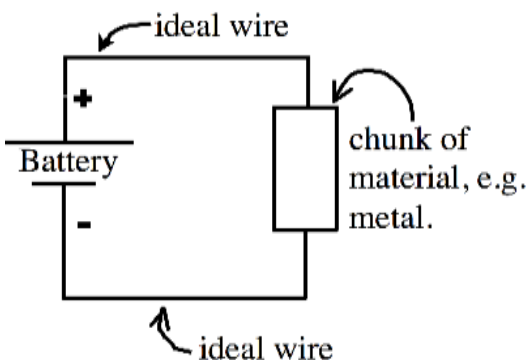

Symbol for ideal _____ wire:

Symbol for chunk of material that allows current through:



Now we’ve provided an

outside path, a *conducting path*, or *circuit*, for charges to flow from the + to - sides of the battery they want to. There is a current flowing continuously through the circuit.. This is a simple electric circuit.

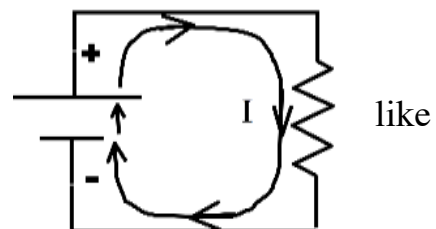

This is NOT like discharging a capacitor (where the flow is quick, and then stops when the capacitor is discharged). The battery keeps maintaining a constant voltage difference, the current is continuous. (As long as the chemical reactions inside keep doing their thing, anyway!)

Example: A bike light’s battery drives 2A of current through the bulb. How much charge has flowed in one hour?

Answer: $I = Q/t$, so $Q = I*t = (2 \text{ A}) * (3600 \text{ sec}) = 7200 \text{ C}$

This corresponds to $7200 \text{ C} / (1.6\text{E-}19 \text{ C/electron}) = 5\text{E}22$ electrons have flowed through the bulb! (Sounds like a lot, although 2 A really isn't an unusual current. Electrons are small. If 7200 Coulombs all piled up in one spot, THAT would be a lot, but this kind of FLOW is normal)

Some important concepts to be aware of:

1) In “ideal wires”, electrons are free to roam around. In good (perfectly) conducting metal it takes *zero* work to move electrons around. Metals like to be at an equipotential throughout, if they can.

There is no voltage drop along ideal wires. This is funny, think about it!

2) Charge is conserved. In steady state circuits, that means there is no buildup of charge anywhere. Whatever charge comes in to some point must go right on by, and out the other side. (This too requires thought!)

In that last example:

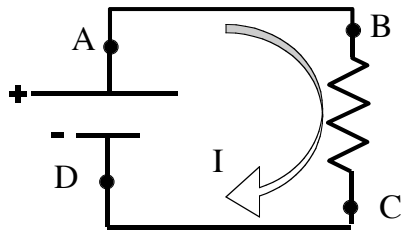

Current (I) is the same *everywhere* along this circuit. That means
 $= I$ through the wires =
 $= I$ through the “chunk of material” =
 $= I$ through the battery =
 $= I$ passing by point A (I_A) =
 $= I_B = I_C = I_D$.

Also, $V_A = V_B$ (because, there is no voltage change along ideal wires!)
 $V_C = V_D$ (again, because there is no voltage change along ideal wires.)

However, $V_A - V_D = “V$ of battery” is fixed, $V > 0$.

Look at the picture and convince yourself that this means

$V_B - V_C = V_A - V_D = V$ (of battery) also.

The order of those terms matters: V_B is *higher* than V_C

Everything I said above will make sense when you've thought about it, but you can't memorize this sort of thing. You have to see it, you have to figure out a way to understand it all. Walk through the circuit above, think about what we're saying - current is the same EVERYWHERE. Voltage is high in some spots, and lower in others, can you picture it?

Resistors:

Any real-life chunk of normal material, even metal, will resist the flow of electric charge. We call such material “resistors”.



What does this mean? Electrons *can* flow through resistors, but not with quite the ease of an ideal wire. They will lose a little energy along the way. It doesn't mean electrons get “eaten up” (charge is conserved, electrons *cannot* disappear), it just means they give up some *energy*.

Experimental observation for many ordinary materials (particularly most metals) shows that if there is a voltage difference ΔV across the material then a predictable, well-defined current will flow through it.

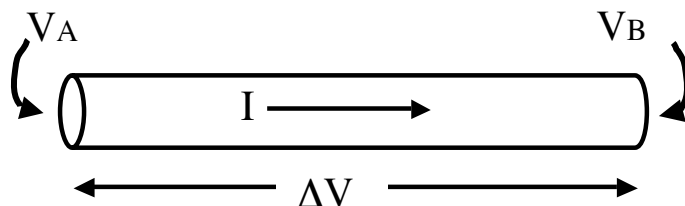

Doubling the voltage drop will double the current flow, i.e. $\Delta V \propto I$.

Equivalently (dropping the Δ , as we often do)

$V = IR$. This is called “Ohm’s Law”. (But really, we SHOULD say $\Delta V = IR$.)

It’s an approximate formula of nature, not a fundamental law.

R is the constant of proportionality, called the “resistance” of the material, $R = V/I$. It depends on the material, and its shape.

Units: $[R] = \text{volts/amps} = V/A = \text{Ohm} = \Omega$ (Greek Omega).

Note: $1\Omega = 1 V/A = 1 (J/C) / (1 C/s) = 1 J*s/C^2$, yikes!

The smaller R is, the less ΔV you need for a given current.

Or equivalently, the smaller R is, the more current you’ll get for a given voltage drop. (Read that again! Think about it...)

(Ideal wires have $R=0$, so $\Delta V=0$ along them, as we’ve said before.)

In real metals, electrons bump into charged ions and slow down. It’s kind of like friction. This is what causes resistance, microscopically. You need a voltage drop to force current to flow.

Example: The bike light in our last example had $I=2$ A. Suppose it has two “AA” 1.5 V batteries in series, like this:

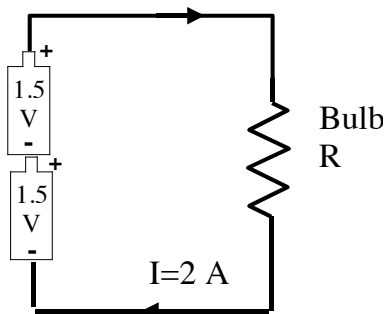

What is the resistance, R , of the bulb?

Answer: We must first decide what the voltage drop V is across the bulb.
(Is it 0 V? 1.5 V? 3 V?)

The total voltage difference, from top to bottom, is 3 V.

Can you see this? Remember, a “1.5 V” battery doesn’t mean that the end labeled “+” is at 1.5 V. It merely means that the + end is 1.5 V HIGHER than the - end.

That means the voltage drop from the top of the bulb to the bottom is 3V, i.e. there are 3 V across the bulb.

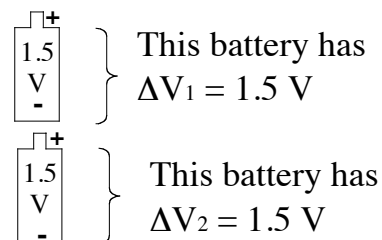

$V = IR$ means $R = V/I$, or $R(\text{bulb}) = 3 \text{ V} / 2 \text{ A} = 12.5 \text{ Ohm}$.

Note: If you stacked one battery upside down in the above circuit, the bulb won’t light up. Can you see why? In this case, $\Delta V(\text{total}) = +1.5 - 1.5 = 0 \text{ V}$.

There is no voltage drop across the bulb, no current flows.

(This is why you have to follow the little picture for “battery orientation” in your iclicker, or flashlight, or the bulb won’t light up)

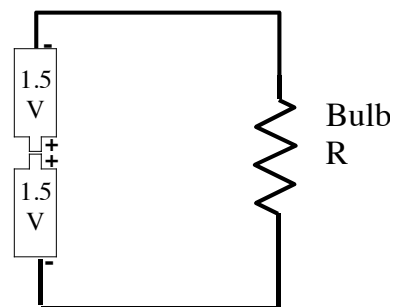

For metal wires, R depends on the material, and also on the shape.

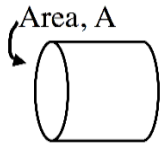

Short or fat wires have smaller resistance.

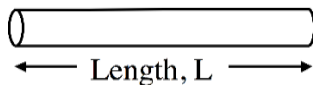

Long, or skinny wires have larger resistance.

The area dependence can be a little confusing to some people.

I like to think of water flowing through pipes. Big wide pipes offer lots of area for the water to spread out, i.e. *low* resistance to flow. Narrow pipes are harder to force water through. (And if there's friction, the longer the pipe, the more resistance there is...)

Empirically, you find R is proportional to L (longer wire \Rightarrow more resistance) and R is proportional to $1/A$ (fat wires, like fat pipes, have smaller resistance)

Putting this together, $R = \rho L / A$

Here, ρ is a constant, called the “resistivity”.

ρ is NOT the density (same symbol, different physics) You have to look it up in tables. It depends on the material, but NOT the shape - that's been factored out.

Typical metals have $\rho = 1\text{E-}8$ Ohm*m or so.

Example: Some Cu wire in class demos has 2 mm diameter. Suppose I cut a 2 m long piece (about 6 ft.) What is the resistance of this wire?

Answer: Look up the resistivity for copper in Giancoli: $\rho = 2\text{E-}8$ $\Omega\cdot\text{m}$.

That's a property of the metal, no matter what the shape.

And remember, area = $\text{Pi } r^2 = \text{Pi } (\text{diam}/2)^2$.

$R = \rho L/A = 2\text{E-}8$ $\Omega\cdot\text{m}$ (2 m) / pi (1E-3 m)² = 0.01 Ω (pretty small.)

Real wires *do* have small resistances. They're almost ideal.

(Notice how the units worked out too - resistivity has *different* units than resistance.)

There are several analogies that might help you think intuitively about V , I , and R in circuits.

Analogy #1: Voltage tells about electrical potential energy, so think of *gravitational* potential energy instead, as the analogue.

- Think of flowing charges as people sliding around at a ski area.
- Think of batteries (which lift charges up to high voltage) as chair lifts that lift people up to high (gravitational) potential.
- Think of resistors (which allow current flow, but eat up energy) as bumpy mogul runs, which let people ski past, but slow you down.

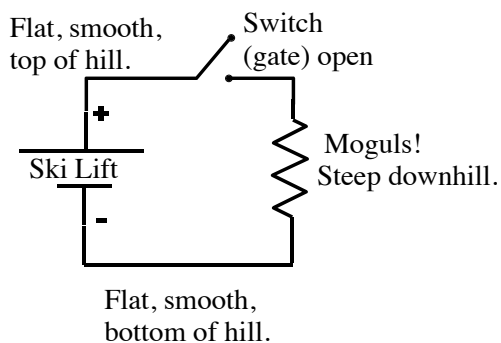

I added a new circuit element here, a switch. As shown, it's “don't pass”,

Unfortunately, this is called an “open switch”, (but that *means* the run is closed, no current can flow.)

As shown, we have an “open circuit”, the open gate is forbidding flow: no flow of skiers, no current. (People will build up briefly at the top, but the lift operators will frantically call down and say “hold up, no more people!” and there'll soon be no flow of skiers anywhere)

When you close the switch (which unfortunately means “open the run”) skiers (current) flows. In steady state, equal numbers of UP the lift every hour as go DOWN the run hour.

The ski lift is a pump, a battery, giving skiers energy, keeping the current flowing. If the lift flow of skiers halts.

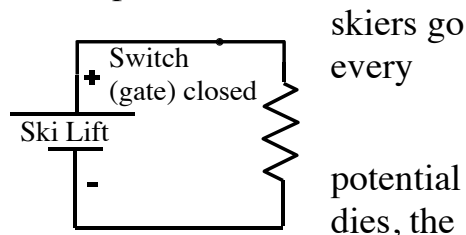

skiers go every potential dies, the

The lift raises your potential energy. You're not allowed to ride the lift DOWN, you have to ski.

The “flat smooth” parts are ideal wires. Skiers can freely wander forwards or backwards at the top (or bottom) with no change in energy.

Lots of bumps in the mogul means lots of resistance. People ski slowly. Only a *small* number of people can go down the hill every hour. So, only an equal small number of people can go up. (They better not let any more people on the lift than come down, otherwise there's a buildup of people, which is forbidden at this ski area!)

The resistance here is high, the current is small.

If the ski run is smooth and easy => LOW resistance => lots of people will go down in a short time. There's a large *current* of skiers. The lift has to bring lots of people up, the steady state current is high.

If the run ices up (no resistance at all) we have big trouble. People get hurt, the lift goes crazy trying to bring everyone up fast enough, because they're back down at the bottom essentially instantly. The lift will quickly break down, it'll fry. It's a "short circuit"!

If lift #1 raises you V_1 feet, and lift 2 raises you V_2 feet, you've gone up a total of V_1+V_2 feet.

(We call this "batteries in series". It's like the problem a few pages back.)

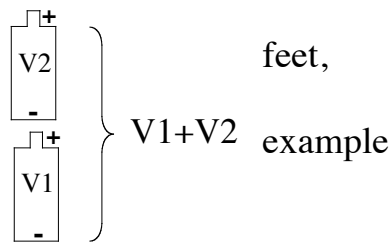

On the way down, you lose EXACTLY the same height (potential energy, voltage) as you gained from the lift on the way up. That's just conservation of energy.

Inside the mogul run (R), people (+ charges) flow DOWNHILL, from high voltage to low voltage.

Inside the lift (battery), people (+ charges) are lifted UPHILL, from low voltage to high.

We'll come back to this analogy later, when we have more complicated circuits. It's definitely not perfect, but sometimes it can help you physically picture what's going on.

Analogy #2: Water flow. (Physicists really like this analogy, but frankly my intuition about pipes and pumps and pressure isn't much better than my intuition about circuits! But here it is for you to think about, anyway.)

Think of current as “gallons of water/sec”

Think of voltage as “water pressure”.

Think of wires as pipes, and resistors as constrictions in pipes.



If $P_1 = P_2$ (no pressure DIFFERENCE), then there is equal force on the water in the middle. There's no *flow*. Similarly, if $V_1 = V_2$, there's no *difference* in voltage across the resistor, and $I = \Delta V/R = 0$.

On the other hand, if $P_1 > P_2$, you have high pressure on one side (like, e.g. the faucet), and a constriction (e.g. the hose) and low pressure on the far side (e.g. the air outside the hose), and water will flow. Just like current through a resistor with a voltage drop.

So a circuit looks like this:

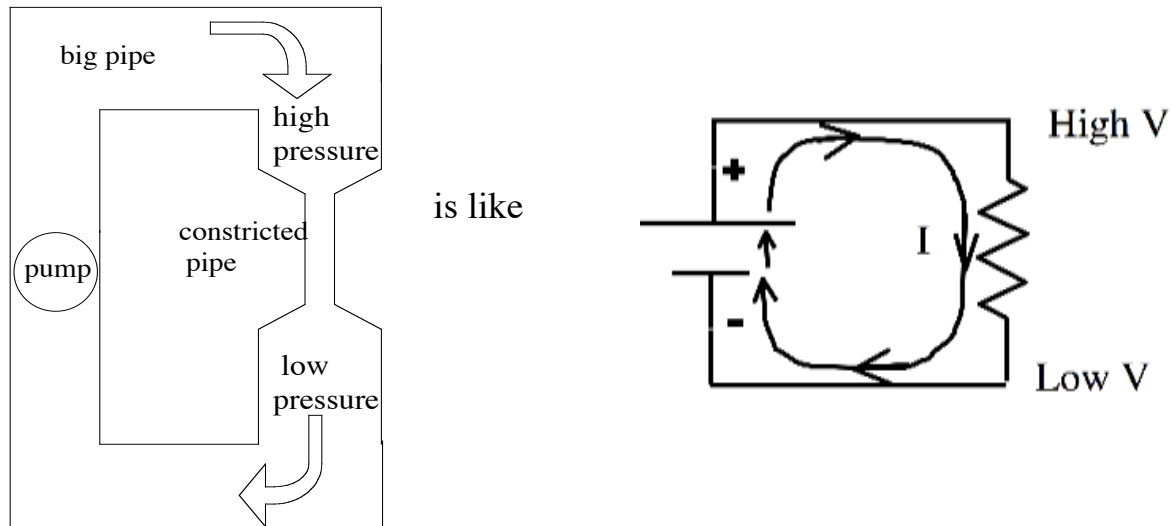

Power and energy in circuits:

When current flows through a resistor, electrons are bumping into atoms (like skiers hitting the moguls): it's like friction, energy is getting dissipated. (Electrical PE is being converted into heat)

Recall our definition of power, energy converted per sec: $P = \Delta E / \Delta t$.

Unit of power is $J/s = \text{Watt} = W$.

Now think of current running through a resistor.

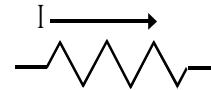

There is a voltage drop “V” across the resistor.

Remember what “voltage drop” *means*: voltage drop is the change in electrical energy per unit charge: $\Delta V = \Delta \text{Energy} / Q$

Since voltage drop is just called V here, then the energy drop is $Q * V$,

and power dissipated = $\Delta \text{Energy} / \text{time} = QV/t = (Q/t) V = I V$.

This is a very important result: $\boxed{P = IV}$,

Power = current * (change in) voltage.

- Don't forget we keep dropping the Δ , what we *mean* by V in that formula is the change in voltage. (So, I really should write it as $P = I \Delta V$)

For normal resistors, Ohm's laws says $V = IR$ (or, $I = V/R$).

That means we could rewrite $P = IV$ as $I^2 R$ or as V^2/R

All equivalent and correct, for “Ohm's law” resistors. For any other system, you should just use the fundamental formula $P = IV$)

Which of those 3 forms (IV , $I^2 R$, or V^2/R) should you use when solving problems? It depends on what's given, and perhaps what is constant.

E.g. if a battery is attached across a resistor, V is constant and given, so it's probably most practical to use $P = V^2/R$. But you have to look at each problem and think about it, there's no general rule...

Example: A 100 W bulb is plugged into a 120 V wall socket.
What's R of the bulb? What is the current I flowing through the bulb?

Answer: There are many ways to go about this. Here's one:

$$P = V^2/R, \text{ so } R = V^2/P = (120 \text{ V})^2/100 \text{ W} = 144 \text{ Ohm}$$

$$\text{Unit check: } V^2/W = V^2/(J/s) = V*V/(J/s) = V*(J/C)/(J/s) = V/(C/s) = V/A = \text{Ohm!}$$

So it worked out. I admit - units can get a bit nasty in this business!

$$\text{Next, } P = V*I \text{ tells us } I = P/V = 100 \text{ W}/120 \text{ V} = 0.83 \text{ A.}$$

Or, alternatively, $P = I^2 R$ says

$$I = \sqrt{P/R} = \sqrt{100\text{W}/144 \text{ Ohm}} = 0.83 \text{ A,}$$

gives us another little check on our answer...

Resistance of real-life materials will change with temperature. (Moguls get slushy when its hot, too.) *Usually*, for normal metals, higher *temperature means more resistance*. Lots of modern thermometers work by using this fact: measuring R of a material and comparing with the nominal (standard) value directly tells you the temperature!

Light bulbs in the US are usually plugged into 120 V sockets.

Since $V=IR$ (and V is fixed at 120 V) then when the bulb is COLD (*low R*), I must be *big*. Later, after the bulb has warmed up (and bulbs heat up a *lot!*) R is larger, so the current flowing through it is smaller.

Have you noticed that light bulbs usually burn out when you *first* turn them on?

They're coldest then, so R is lowest: the current is (momentarily) largest, and $P = IV$ is therefore also momentarily the largest: the big rush of current/power breaks the fragile filament. Once it's warmed up, it's much less likely to break (unless you jiggle it)

I've been cheating a little in the last examples, because the 120 V in your wall socket isn't quite like a battery: V really oscillates in time:

AC Voltage and Current:

Batteries produce a steady, fixed voltage, called DC, or direct current. (We should probably call them DV, direct voltage, but never mind)

The power company produces a time-varying voltage, AC, or *alternating current*.

(See Giancoli Fig 18-21 for a sketch of current vs time, or Fig 21-18 for a sketch of voltage vs. time:., either just looks like a sinusoidal oscillation) The PERIOD “T” is the amount of time for the oscillating voltage to go through one full cycle, from max to min to max again.

The mathematical formula for AC voltage is:

$V(t) = V_0 \sin(2\pi f t)$. (Your calculator MUST be in radian mode!)

V_0 is called “peak” or “maximum” voltage.

In the USA the period $T = 1/60$ s, so frequency $f = 1/T = 60$ Hz.

(In Europe, it's closer to 50 Hz).

A simple circuit diagram for a light bulb (which is basically a resistor) plugged into the wall might look like this:

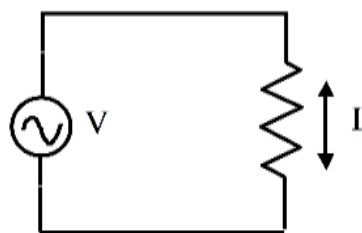

The squiggle on the left is the symbol for an AC voltage source, rather than a battery.

The current no longer has a definite direction: since the voltage changes with time, so does I .

In fact, we can figure out $I(t)$ easily from Ohm's law:

$$I(t) = V(t)/R = \frac{V_0}{R} \sin(2\pi f t) = I_0 \sin(2\pi f t) .$$

Here, we have found the maximum current $I_0 = V_0/R$.

Clearly, current I alternates right along with V (hence the name AC)

Ohm's law continues to hold in AC circuits, and $V_0 = I_0 R$...

The voltage $V(t)$ is symmetric, it's + as often as -, it averages to 0.

We say $V(\text{ave})=0$ (or $\bar{V}=0$)

Similarly, $I(t)$ is also oscillating about 0, $I(\text{ave}) = 0$.

Recall that $P = IV$, so what is the average power, \bar{P} ?

(You *might* guess zero, but think about light bulbs: average power used by real bulbs surely can't be zero, otherwise they'd be free)

At any moment in time, $P(t) = I(t)*V(t) = I_0 V_0 \sin^2(2\pi f t)$.

If you graph this, the "sin squared" changes things a bit, see Giancoli Fig 18-22 for a little picture. In the old period "T" the curve actually goes through TWO peaks (because when you square it, the NEGATIVE peak of voltage gets squared, to become a POSITIVE peak of power)

$\sin^2(\text{anything})$ is always positive.

$\sin^2(\text{anything})$ runs from 0 up to 1 and back again.

On average, it is 1/2.

That means $\bar{P} = (1/2) I_0 V_0$. (It is *not* zero.)

Here's an odd question: "what's the average of the *square* of voltage?" (It may not seem obvious why I'd care, but then remember $P = V^2/R$, so V^2 *does* appear in formulas... We really will care about this.)

Remember, $V(\text{ave})=0$. So you might think the average of V^2 is zero - but no! Just like the power example above: $V^2(t) = V_0^2 \sin^2(2\pi f t)$, and the average value of \sin^2 is 1/2, not 0: $V^2(\text{average}) = V_0^2 / 2$.

The "average of the square" is NOT the square of the average (which was zero)!

Now we have another way to find average power: find the average of $P=V^2/R$, which (we just showed) is $P(\text{ave}) = (1/2)V_0^2/R$.

(It's really the SAME result as the previous page, namely

$P(\text{ave}) = (1/2) I_0 V_0$, because remember $I_0 = V_0/R$.)

People have even given a name to $\text{Sqrt}[V^2(\text{average})]$.
They call this V_{rms} , the “root mean square” voltage

From its definition (just square both sides): $V_{\text{rms}}^2 = V^2(\text{ave})$.
Now, plugging in my result above for $V^2(\text{ave}) = (1/2) V_0^2$ gives

$$V_{\text{rms}} = V_0 / \text{Sqrt}[2]$$

The rms voltage is *not* the average voltage (which is 0), but it’s kind of a “representative” voltage. After all, voltage runs from $-V_0$ to $+V_0$, it’s (almost) always less than V_0 , so $V_0/\text{Sqrt}[2]$ is kind of a more “typical” voltage...

Similarly, $I_{\text{rms}} = I_0 / \text{Sqrt}[2]$ gives the typical current.

Now, remember, we had old (DC) formulas that said
 $P = IV = I^2 R = V^2/R$.

The new (AC, but averaged) formulas we just derived say
 $P(\text{ave}) = (1/2) I_0 V_0 = (1/2) I_0^2 R = (1/2) V_0^2/R$.

That recurring factor of $(1/2)$ is annoying, and perhaps confusing.
It’s there because we’re writing average power in terms of *maximum* I and V .
If instead we rewrote $P(\text{ave})$ in terms of rms values, we’d get a nicer result:

$$P(\text{ave}) = I_{\text{rms}} V_{\text{rms}}. \quad (\text{Check that - convince yourself it’s right.})$$

The AC average formula LOOKS like the old DC formula, exactly:
no factors of 2 at all, if you just use rms values instead of “peak” values.

$$P(\text{ave}) = I_{\text{rms}} V_{\text{rms}} = I_{\text{rms}}^2 R = V_{\text{rms}}^2/R$$

(Convince yourself that they’re *all* right)

Example: US Wall sockets really have $V_{\text{rms}} = 120 \text{ V}$. What is the *peak* voltage, V_0 ?

Answer: $V_0 = \text{Sqrt}[2]*V_{\text{rms}} = 170 \text{ V}$.

The US wall voltage is NOT running from -120 V to $+120 \text{ V}$.

It's really running from -170 V to $+170 \text{ V}$.

On average it is 0, but it has a "typical" value of 120 V .

In particular, when computing POWER, you can just pretend it's

120 V DC , and just use the old familiar power formulas.

That's why people say "the wall is 120 V "; they really MEAN V_{rms} .

In Europe, $V_{\text{rms}} = 240 \text{ V}$. This causes serious problems if you try to plug a US appliance into a European socket, or vice versa.

E.g., consider a 100 W bulb purchased in the US. Plug it into the wall in Europe.

The resistor, R , is the same of course, but V is different.

Since $P(\text{ave}) = V_{\text{rms}}^2/R$, and V_{rms} is about 2 times bigger there,

squaring gives 4 times more power. It becomes a 400 W bulb, but it's not designed to dissipate all that heat - it'll burn out immediately.

(If you go the other way, and plug a European 100 W bulb into the wall here, what will happen?)

Example: Earlier, we computed R for a short piece of Cu wire, and got 0.01Ω .

What's the average power dissipated in this wire, if a current of $I_{\text{rms}} = 25 \text{ A}$ runs through the wire into a big appliance?

Answer: $P(\text{ave}) = I_{\text{rms}}^2 * R = (25 \text{ A})^2 * (0.01 \Omega) = 6.3 \text{ W}$.

That's quite a lot of power. (A toaster might dissipate 500 W or so) The wire will certainly heat up. Even though R is small, it's not 0. If you let appliances consume too much current, the wires in your house could easily start a fire. That's why you have *fuses* (typically rated at $15\text{-}20 \text{ A}$). A fuse is a little device that shuts off all the current in a circuit if it ever exceeds the rated value.

The circuit symbol for a 15 A fuse is



Electric costs:

The power company does not charge for power (!)
It sells you *energy*. Power = Energy/time, so
Energy = Power*time.

They don't really care if you use a LOT of power for a short time,
or a little power all the time, they charge you for the product: energy.

My public service bill charges me about 10 cents/ (kW hr).
That's pretty cheap by national standards, by the way, and I'm paying 2 cents more
than most people to get wind-power...

Those are really the units on my bill. A kW·hr is a unit of ENERGY,
 $1 \text{ kW}\cdot\text{hr} = 1000 \text{ W} * 1 \text{ hr} = 1000 \text{ J/s} * (3600 \text{ sec/hr}) = 3.6\text{E}6 \text{ J}$.
(10 cents for 4 Mega Joules of energy. It's really stunningly cheap!!)

Example: You buy an electric space heater, rated at 1 kW.
(That's a pretty typical power rating for a big appliance. A blow-dryer might even
be 2 kW)
You leave it on in the basement, day and night, from October - March, through the
cold months.
How much have you paid, extra, on your electric bills?

Answer: Let's convert 6 months into hours:
 $6 \text{ mo} * (30 \text{ days/month}) * (24 \text{ hrs/day}) = 4300 \text{ hours}$.

You used energy $E = P(\text{ave}) * \text{time} = 1 \text{ kW} * 4300 \text{ hrs} = 4300 \text{ kW}\cdot\text{hrs}$.

Cost to you is about $4300 \text{ kW}\cdot\text{hrs} * 10 \text{ cents/kW}\cdot\text{hr} = \430 . Yikes!

(There are more efficient ways of heating a space than electric heaters. All-electric
heat in houses is pricey and it'll only get worse as energy costs start climbing in
the near future! Might be better to at least first insulate the room well.)